

ONLY USE

our original

Leatherpackings and Spare Parts.

To be obtained from all leading shiphandlers.

Beware of imitations!

More than 60.000 TYFON Signals in use all over the world.

There is a TYFON for every signal purpose — maritime or stationary. For small vessels and up to the giants of the Oceans, for Railway purpose, firealarm, timesignals etc.

Let us know your problems and we will be pleased to submit you a proposal.



Registered Trade Mark.

PRINTED IN SWEDEN

76924 PERFEKTA-TRYCK, ARLÖV

Directions for use

for

TYFON T 75 BG

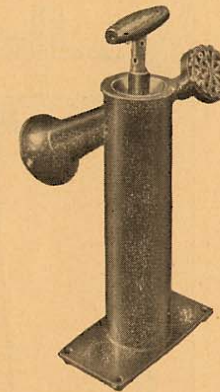

KOCKUMS

MEKANISKA VERKSTADS AKTIEBOLAG
MALMÖE - SWEDEN

Shipbuilders and Engineers since 1840

No. 672.

"TYFON" T 75 BG

consists of an
air pump and the TYFON.

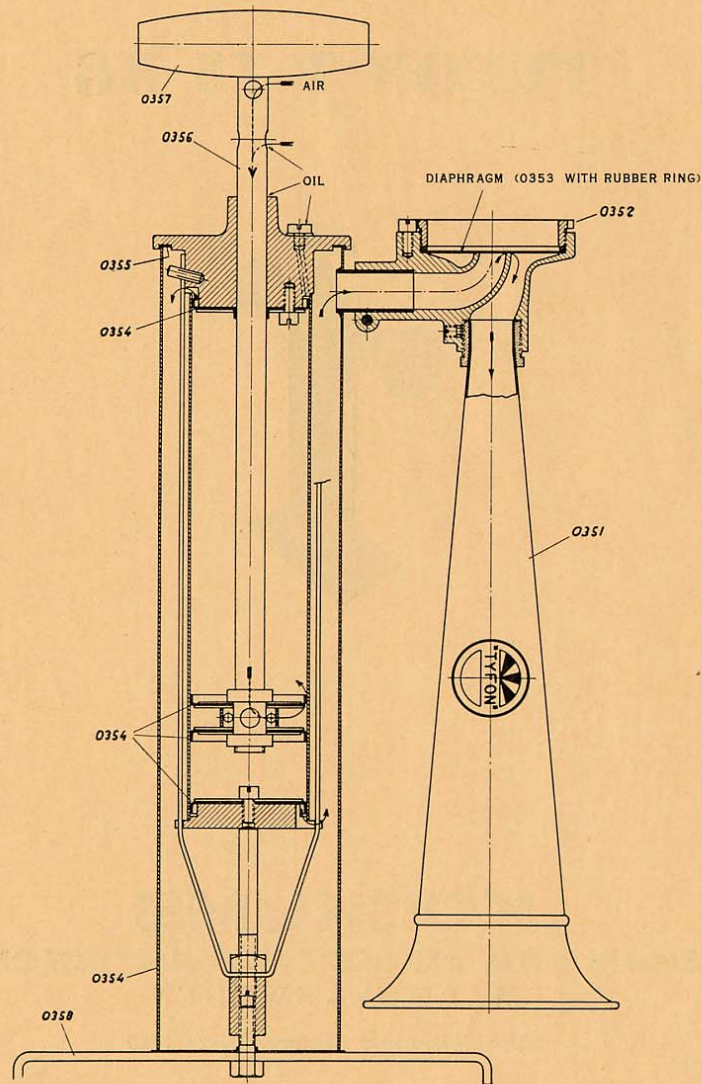

TYFON. Sound is produced in the Tyfon by means of a thin brass diaphragm, which at every vibration strikes against the edge of the exhaust pipe. If dirt gets caught between the diaphragm and this edge the sound produced will not be pure. To clean the apparatus the lock-screw is first unscrewed and then the cover taken off. After wiping the Tyfon the cover is fixed on in that position, where a pure tone and the most powerful sound is obtained. This is easily found by pumping and turning the cover simultaneously.

NOTICE! See that the rubberring gets in its place between diaphragm and cover (0352).

PUMP. The leather packings of the pump (0354—55) should be kept well oiled. This is done when necessary by injecting the thinnest lubricating oil (e. g. sewingmachine oil) through intake openings in the pump rod as well as on the edge between the pump rod and the pump as well as at the screw marked OIL. The oil is then distributed by pumping vigorously and turning the pump rod. By screwing off the central nut under the foot plate and then loosening the screw, that strains the bow, the pump can completely be dissembled for cleaning.

In reassembling it is of the greatest importance to see:

- that* the inner surface of the pumpcylinder is free from old oillayers and well cleaned, smooth and carefully oiled,
- that* the packings are correctly placed when changed. See the section to the left,
- that* all the leather packings are carefully oiled with oil as above. Especially new leather packings must be drenched with oil,
- that* the leather packings do not get jammed,
- that* the pumppipe is fixed properly,
- that* the packings, which tighten against the edges of the outside pipe, do not get damaged,
- that* the pipes everywhere rest and tighten against these packings and not on the outer edges of the cover or the bottom.